



600-VOLT SYSTEMS

solar electricity

128/121/115 WATT

THIN FILM MODULE

Amorphous Silicon/Microcrystalline Silicon
UL-Listed for 600-volt systems

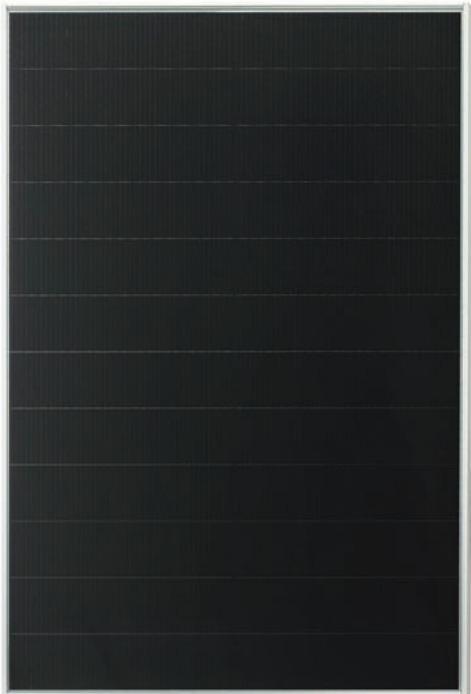

NA-V128H1 | NA-V121H1 | NA-V115H1

THIN FILM PHOTOVOLTAICS: THE NEXT EVOLUTION OF SOLAR TECHNOLOGY

Sharp's thin film product pairs amorphous silicon with a layer of microcrystalline silicon to achieve high stability and performance. Produced with less than one percent of the silicon used in crystalline solar cells, thin film products offer high performance with less semiconductor material. With a low temperature coefficient for output power, thin film generates greater energy than its crystalline silicon counterpart in geographic regions where temperatures are high. In warm climates, this translates into more kilowatt-hours per kilowatt.

**Sharp: The first name in solar power.
The last word in solar innovation.**

Offering one of the most efficient thin film photovoltaic products ever manufactured, Sharp becomes the provider of choice for multi-megawatt-scale power production.

ENGINEERING EXCELLENCE

Tandem-junction structure (amorphous silicon/microcrystalline silicon) captures a wider part of the solar spectrum, converting more sunlight into electricity.

HIGH VOLTAGE ADVANTAGE

Proprietary design increases reliability by minimizing losses caused by module output variation.

RELIABILITY

Microcrystalline layer provides superior long-term stability and higher module efficiency.

DURABLE

Four bypass diodes ensure maximum output under non-uniform operating conditions.

INNOVATIVE

Single-layer glass with polymeric backskin lowers pounds per watt and transportation costs. Modules are sized to optimize the greatest amount of power, easily handled by one person.



340 kW, German factory rooftop

LEADING THE FUTURE OF SOLAR

Since 1959, Sharp has led the solar electric industry with efficient, affordable systems and powers more homes and businesses than any other solar manufacturer in the world. From research and development, to system design, delivery, deployment and a more diverse product portfolio, Sharp is ready to partner with you to create customized solar solutions, with an unyielding commitment to quality control and customer service.

BECOME POWERFUL

128/121/115 WATT

NA-V128H1 | NA-V121H1 | NA-V115H1

Amorphous Silicon/Microcrystalline Silicon
UL-Listed for 600-volt systems

ELECTRICAL DATA

Maximum power	P _{max}
Open-circuit voltage	V _{oc}
Short-circuit current	I _{sc}
Voltage at maximum power	V _{pmax}
Current at maximum power	I _{pmax}
Module efficiency	η
Temperature coefficient – open circuit voltage	β
Temperature coefficient – short circuit current	α
Temperature coefficient – power	γ

MADE IN JAPAN

NAMEPLATE VALUES

NA-V128H1	NA-V121H1	NA-V115H1
128	121	115
238	238	238
0.846	0.830	0.810
186 V	180 V	174 V
0.688 A	0.673 A	0.661 A
9.0%	8.5%	8.1%
	-0.3%/°C	
	+0.07%/°C	
	-0.24%/°C	

The electrical data applies under standard test conditions (STC): Irradiance of 1,000 W/m² with an AM 1.5 spectrum at a cell temperature of 25° C. The power output is subject to a manufacturing tolerance of + 10% / - 5%. Output values are post initial Staebler-Wronski decay; actual measured initial values will be greater (approximately 15% for power).

SPECIFICATIONS (I)

Cell	Tandem architecture of amorphous and microcrystalline silicon
Cell Circuit	45 cells in series by 6 in parallel per quadrant: 4 quadrants in series (1080 total cells)
Dimensions	39.7" x 55.5" x 1.8" (1009 x 1409 x 46 mm)
Weight	42 lbs
Connection type	Cable with MC-4 connector
Bypass diodes	4 (one per quadrant)
Fire Rating	Class C

SPECIFICATIONS (II)

Maximum system voltage	600 V _{DC}
Maximum mechanical load	1,600 Pa
Series Fuse Rating	2 A
Operating temperature (cell)	- 40 to +90 °C
Storage temperature	- 40 to +90 °C
Storage air humidity	Up to 90 %
Installation orientation	Portrait

Design and specifications are subject to change without notice. Sharp is a registered trademark of Sharp Corporation. All other trademarks are property of their respective owners. Contact Sharp to obtain the latest product manuals before using any Sharp device.



SHARP®

SHARP ELECTRONICS CORPORATION
5901 Bolsa Avenue, Huntington Beach, CA 92647
1-800-SOLAR-06 • Email: sharpsolar@sharpusa.com
www.sharpusa.com/solar

EXTERIOR DIMENSIONS

BACK VIEW

SIDE VIEW

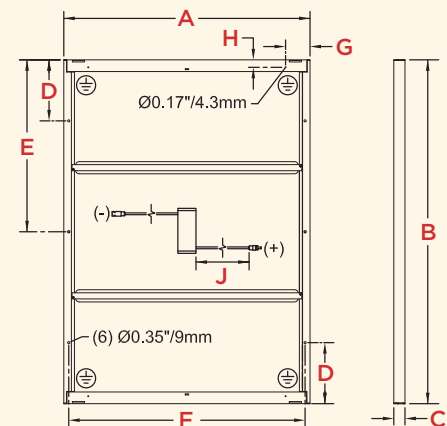

A	B	C
39.7"/1009 mm	55.5"/1409 mm	1.8"/46 mm
D	E	F
9.8"/250 mm	27.7"/704.5 mm	38.1"/969 mm
G	H	J
3.9"/100 mm	1.2"/30.5 mm	35.4"/900 mm



(800) 967-6917
www.dcpower-systems.com